



## **Gdańsk Workshop**

**„Progress in new methods of water and waste water cleaning”**

### **Programme & Abstracts**

**July 4-5, 2011**

**Gdańsk, Poland**

**The Szewalski Institute of Fluid-Flow Machinery  
Polish Academy of Sciences**

## Solar powered ozone installation for water treatment in swimming pools

J. Diatczyk<sup>1</sup>, G. Komarzyniec<sup>1</sup>, R. Muszanski<sup>2</sup>, H. D. Stryczewska<sup>1</sup>

<sup>1</sup>*Institute of Electrical Engineering and Electrotechnologies,  
Lublin University of Technology, Nadbystrzycka 38A, 20-618 Lublin, Poland*

<sup>2</sup>*Wofil Ozone Technology, Rzezniana 10/1, 33-380 Krynica-Zdroj, Poland*

Keywords: ozone generation, water treatment, PV systems, swimming pools.

In the future, the noticeable climatic changes plus the natural environmental pollution may become the cause of the necessity to treat water of a very bad quality in order to satisfy the need for potable water. On the other hand, a greater arrestment of contamination emission into the natural environment may be vital for limiting the application of chemical agents that disinfect drinking water. The simultaneous development of energetic problems will impose greater limitations of electric energy consumption by water treatment and enrichment installations. What may function as a solution to these problems are small water ozonation installations supplied with electric energy from renewable energy sources. Thanks to the usage of ozone in the process of water treatment and in the disinfection process of technological system, there is no need of using any additional disinfectants. Figure 1 depicts a little household water ozonation installation. This system is totally autonomous, designed for a constant work in difficult climatic conditions. The system is made of three basic systems: electric energy power system, ozone production system and water treatment system. The devised technological solution is excellent to be utilized on remote terrains, which are distant from power network or in the places where the power main is unstable and fallible.

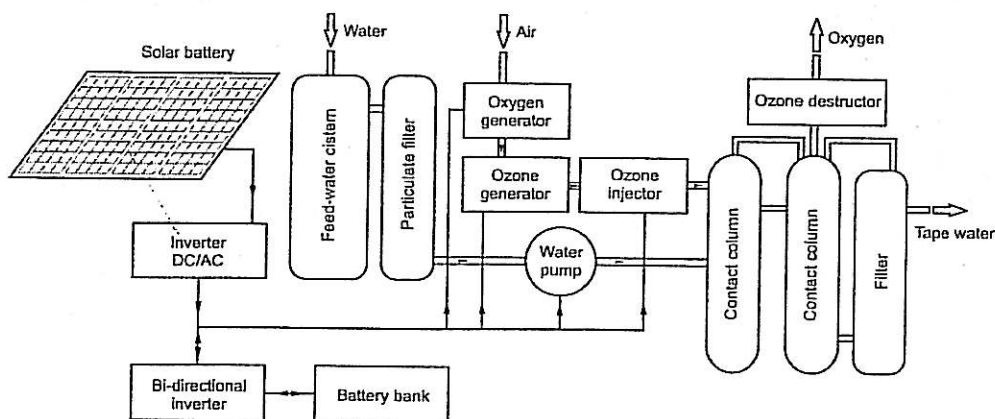

Fig. 1. Water ozonation system